

G



JAY R. SMITH MFG. CO.
 MEMBER OF MORRIS GROUP INTERNATIONAL
 POST OFFICE BOX 3237
 MONTGOMERY, ALABAMA 36109-0237 (USA)
 TEL: 334-277-8520 FAX: 334-272-7396 www.jrsmith.com



MEMBER OF:

LOCATION

PENAL USE VANDAL PROOF SHOWER DRAIN

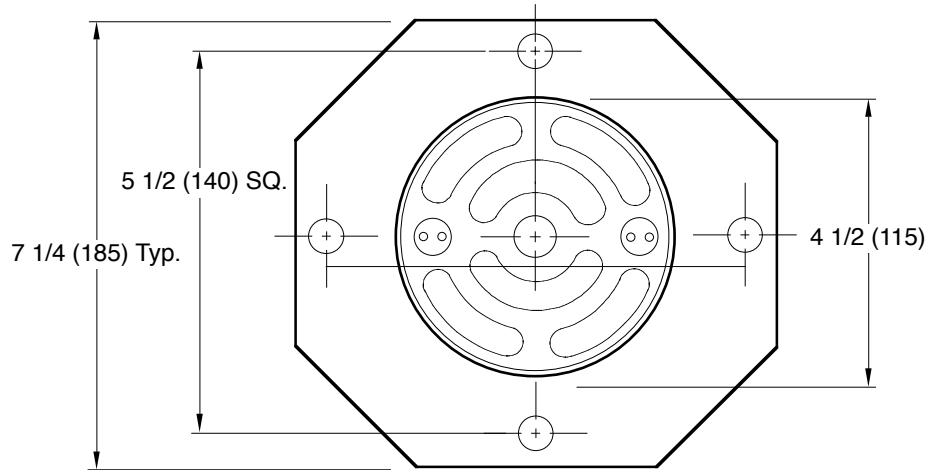

TOP VIEW

5/16(8)-18 x 5/8(16) Zinc Plated
 Flat Head Deck Screws
 (4) Included

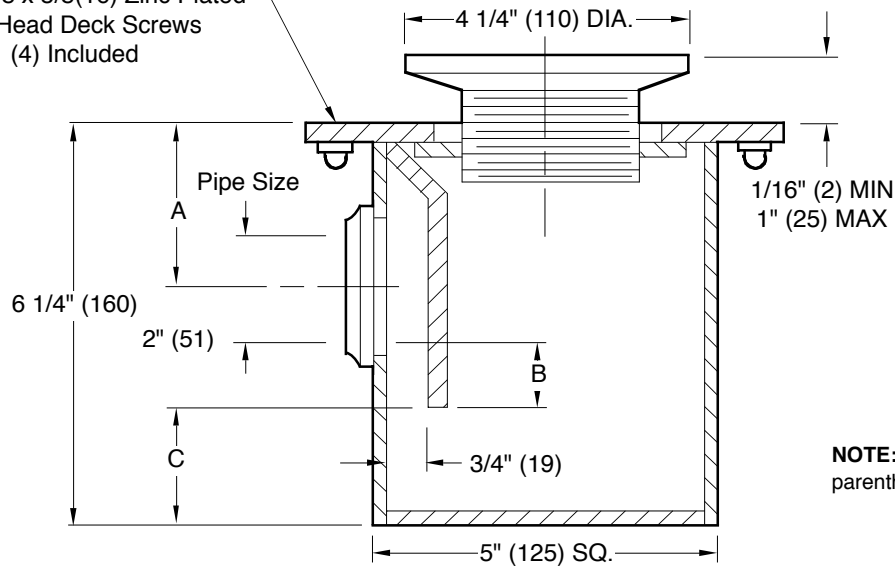

NOTE: Dimensions shown in parentheses are in millimeters.

REGULARLY FURNISHED:

Galvanized Fabricated Steel
 Body, Flanged Deck Top, Vandal
 Proof Polished Bronze Adjustable
 Strainer Head, Integral Trap and
 Threaded Outlet.

Pipe Size	A	B (Trap Seal)	C
0150 (40)	2 1/2 (64)	1 1/4 (32)	1 3/4 (44)
02 (50)	2 1/2 (64)	1 (25)	1 3/4 (44)
03 (75)	3 (76)	1/2 (13)	1 1/4 (32)

REV.	DATE	DESCRIPTION	BY	CKD. BY
G	10-25-16	Revised Regularly Furnished Revised Table Removed Tab from Strainer Head Added Millimeters	TBW	TWK
F	11-30-15		TBW	CL
E	04/28/04		JJ	BW
D	4-8-97		EMB	BS

WEIGHT
POUNDSVOLUME
CUBIC FEET

FIGURE NUMBER

2016

2016

FIGURE
NUMBERDRAWING NUMBER
S2016SIZE
ASCALE:
NONEDATE:
12-11-90APPROVED BY:
McDCHECKED BY:
JMDRAWN BY:
EMB

WE CAN ASSUME NO RESPONSIBILITY FOR USE OF SUPERSEDED OR VOID DATA

DIMENSIONS ARE SUBJECT TO MANUFACTURERS TOLERANCE AND CHANGE WITHOUT NOTICE



WARNING: Cancer and Reproductive Harm - www.P65Warnings.ca.gov