

SCUPPER DRAINS

FUNCTION: Used at junction of roof and parapet or in metal lined gutters. Gasket and metal lining are secured with grate, insuring a watertight arrangement.

Free area
14.5 SQ IN
(94) SQ CM

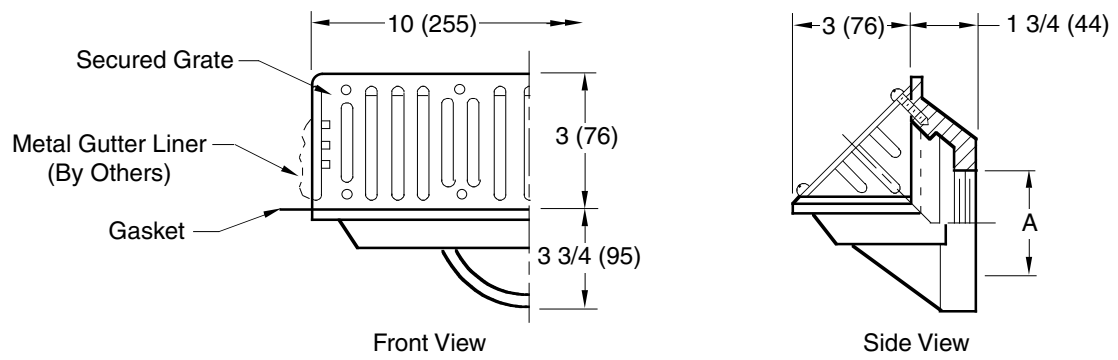

□ Fig. 1560T 90° THREADED OUTLET
A (Pipe Size) = 02(50) or 03(75)

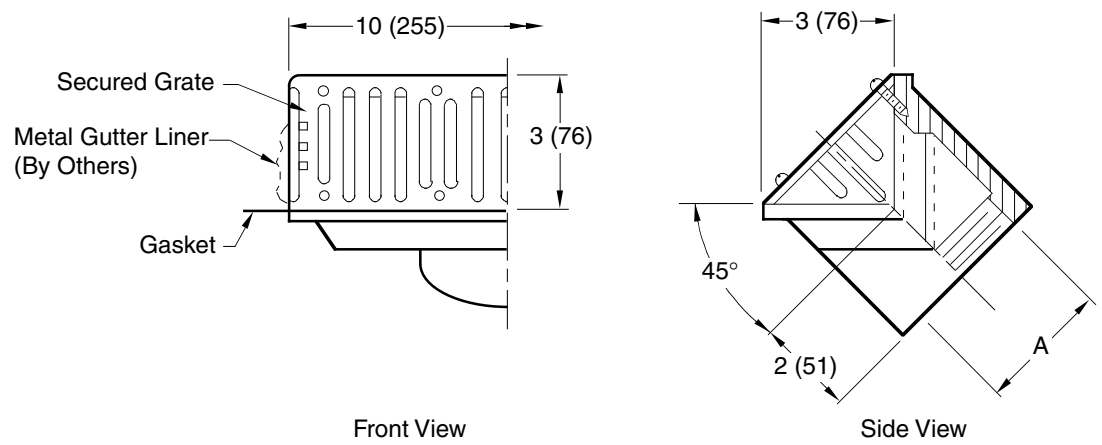

□ Fig. 1570T 45° THREADED OUTLET
A (Pipe Size) = 02(50) or 03(75)

NOTE: Dimensions shown in parentheses are in millimeters.

REGULARLY FURNISHED:
Cast Bronze Body with Combined Rough Bronze Grate and Flashing Clamp and Gasket.

OPTIONAL MATERIALS:
 □ Nickel Bronze Top -NB
 □ Polished Bronze Top -PB

DRAWING NUMBER S1560
 SIZE A
 SCALE: NONE
 DATE: 5-24-85
 APPROVED BY: TD
 CHECKED BY: TD
 DRAWN BY: PL
1560, 1570
 FIGURE NUMBER

WE CAN ASSUME NO RESPONSIBILITY FOR USE OF SUPERSEDED OR VOID DATA

E	6-16-99	Revised Millimeters	CMD	BS		
D	4-7-97	Added Millimeters	EMB	BS		
C	6-30-94	Revised	EMB	BS	WEIGHT	VOLUME
B	6-7-93	Submittal Update	EMB	BS	POUNDS	CUBIC FEET
A	3-90	Gasket Changed	TBW	SB		FIGURE NUMBER
REV.	DATE	DESCRIPTION	BY	CKD. BY		1560, 1570